

Write your name here

Surname

Other names

Centre Number

Candidate Number

Edexcel GCSE

Mathematics A

Paper 2 (Calculator)

Higher Tier

Wednesday 13 June 2012 – Morning

Time: 1 hour 45 minutes

Paper Reference

1MA0/2H

You must have: Ruler graduated in centimetres and millimetres, protractor, pair of compasses, pen, HB pencil, eraser, calculator. Tracing paper may be used.

Total Marks

Instructions

- Use **black** ink or ball-point pen.
- **Fill in the boxes** at the top of this page with your name, centre number and candidate number.
- Answer **all** questions.
- Answer the questions in the spaces provided – *there may be more space than you need.*
- **Calculators may be used.**
- If your calculator does not have a π button, take the value of π to be 3.142 unless the question instructs otherwise.



Information

- The total mark for this paper is 100
- The marks for **each** question are shown in brackets – *use this as a guide as to how much time to spend on each question.*
- Questions labelled with an **asterisk** (*) are ones where the quality of your written communication will be assessed.

Advice

- Read each question carefully before you start to answer it.
- Keep an eye on the time.
- Try to answer every question.
- Check your answers if you have time at the end.

Turn over ►

P40647A

©2012 Pearson Education Ltd.

6/6/7/3/



PEARSON

GCSE Mathematics 1MA0

Formulae: Higher Tier

**You must not write on this formulae page.
Anything you write on this formulae page will gain NO credit.**

Volume of prism = area of cross section \times length



Area of trapezium = $\frac{1}{2} (a + b)h$

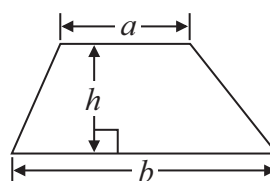

Volume of sphere = $\frac{4}{3} \pi r^3$

Surface area of sphere = $4\pi r^2$



Volume of cone = $\frac{1}{3} \pi r^2 h$

Curved surface area of cone = $\pi r l$



In any triangle ABC



The Quadratic Equation

The solutions of $ax^2 + bx + c = 0$
where $a \neq 0$, are given by

$$x = \frac{-b \pm \sqrt{b^2 - 4ac}}{2a}$$

Sine Rule $\frac{a}{\sin A} = \frac{b}{\sin B} = \frac{c}{\sin C}$

Cosine Rule $a^2 = b^2 + c^2 - 2bc \cos A$

Area of triangle = $\frac{1}{2} ab \sin C$



Answer ALL questions.

Write your answers in the spaces provided.

You must write down all stages in your working.

1

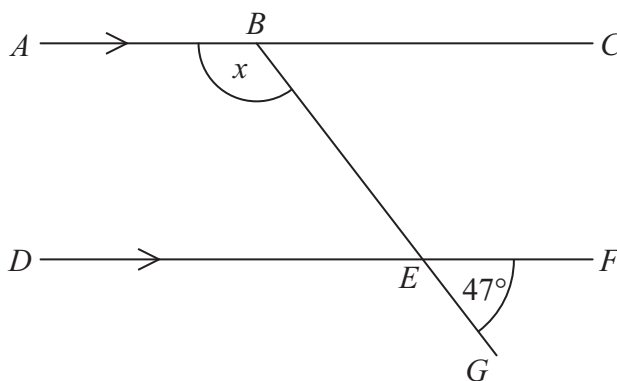

Diagram **NOT** accurately drawn

ABC and DEF are parallel lines.

BEG is a straight line.

Angle $GEF = 47^\circ$.

Work out the size of the angle marked x .

Give reasons for your answer.

.....
(Total for Question 1 is 3 marks)



- 2 (a) Use your calculator to work out $\frac{38.5 \times 14.2}{18.4 - 5.9}$

Write down all the figures on your calculator display.
You must give your answer as a decimal.

.....
(2)

- (b) Write your answer to part (a) correct to 1 significant figure.

.....
(1)

(Total for Question 2 is 3 marks)



3 Pradeep wants to find out how much time people spend playing sport.

He uses this question on a questionnaire.

How much time do you spend playing sport?

0 – 1 hours

1 – 2 hours

3 – 4 hours

(a) Write down **two** things wrong with this question.

1

.....

2

.....

(2)

(b) Design a better question for Pradeep's questionnaire to find out how much time people spend playing sport.

(2)

(Total for Question 3 is 4 marks)



4 On the grid, draw the graph of $y = 3x - 2$ for values of x from -1 to 3

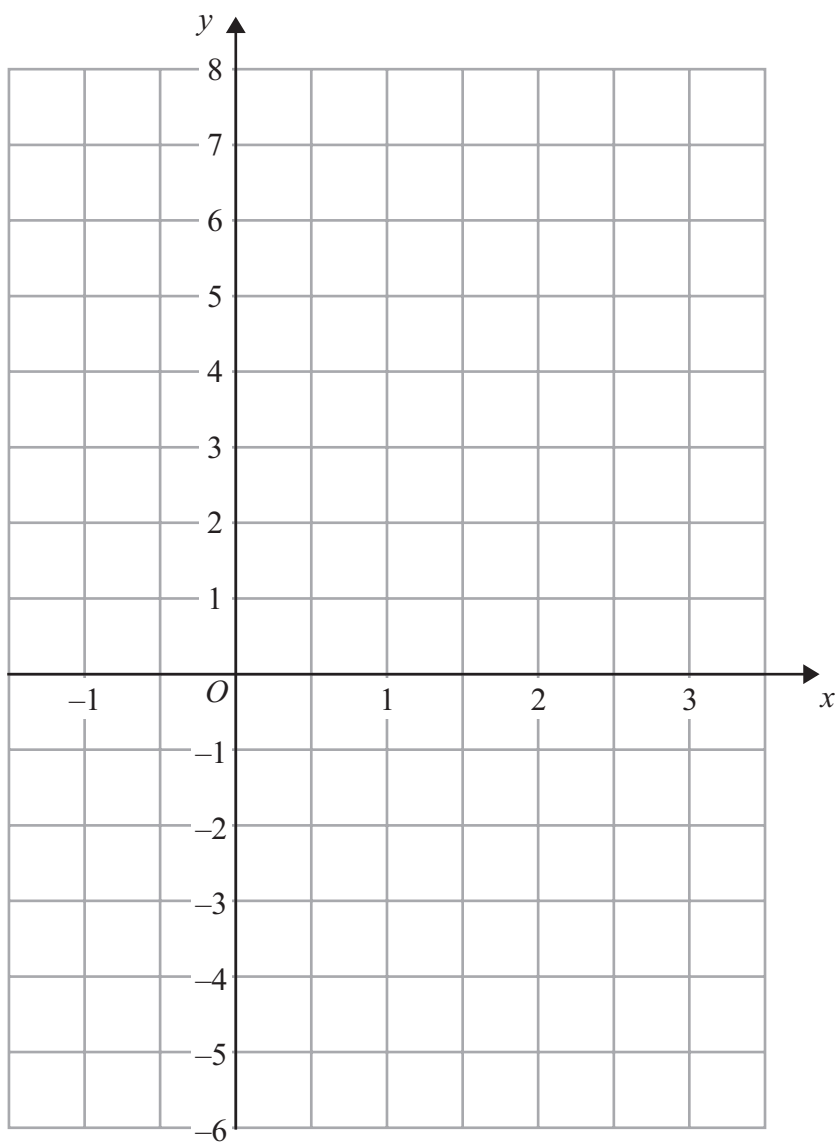

(Total for Question 4 is 3 marks)



*5 Mr Weaver's garden is in the shape of a rectangle.

In the garden

there is a patio in the shape of a rectangle
and two ponds in the shape of circles with diameter 3.8 m.

The rest of the garden is grass.

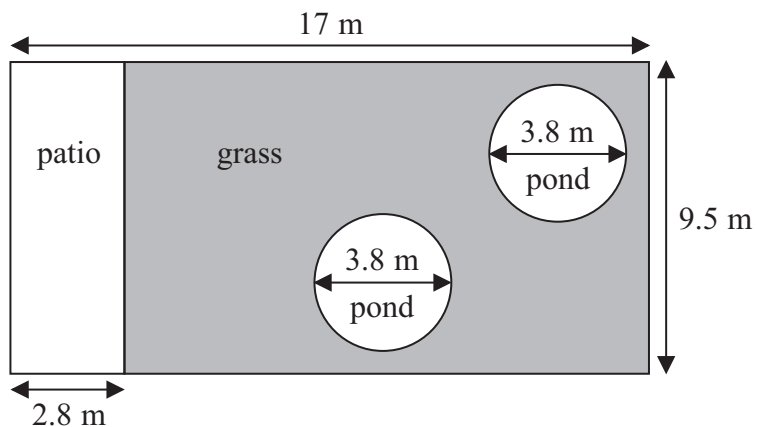

Diagram **NOT**
accurately drawn

Mr Weaver is going to spread fertiliser over all the grass.
One box of fertiliser will cover 25 m^2 of grass.

How many boxes of fertiliser does Mr Weaver need?
You must show your working.

(Total for Question 5 is 5 marks)



*6 Potatoes cost £9 for a 12.5 kg bag at a farm shop.
The same type of potatoes cost £1.83 for a 2.5 kg bag at a supermarket.

Where are the potatoes the better value, at the farm shop or at the supermarket?
You must show your working.

(Total for Question 6 is 4 marks)



- 7 The scatter graph shows some information about 8 cars.
For each car it shows the engine size, in litres, and the distance, in kilometres, the car travels on one litre of petrol.

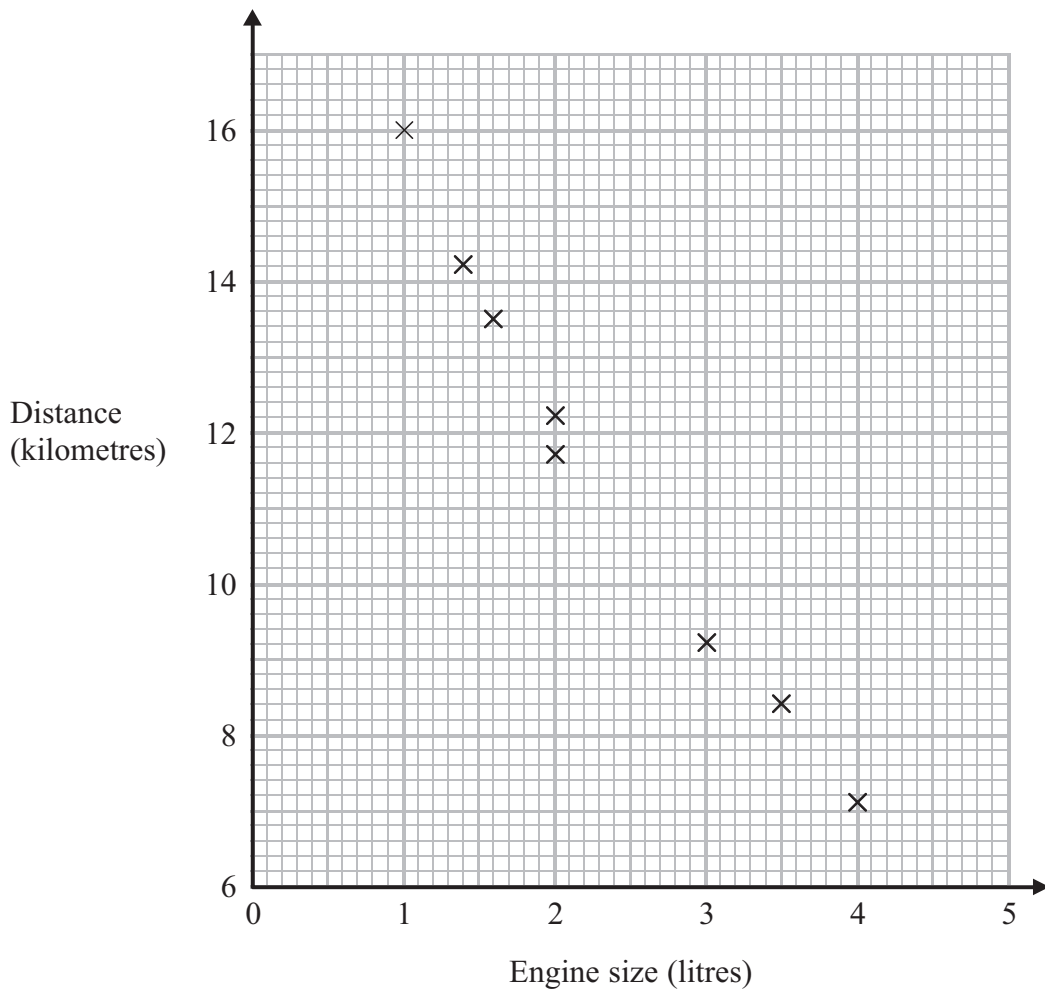

- (a) What type of correlation does the scatter graph show?

.....
(1)

A different car of the same type has an engine size of 2.5 litres.

- (b) Estimate the distance travelled on one litre of petrol by this car.

..... kilometres
(2)

(Total for Question 7 is 3 marks)



8

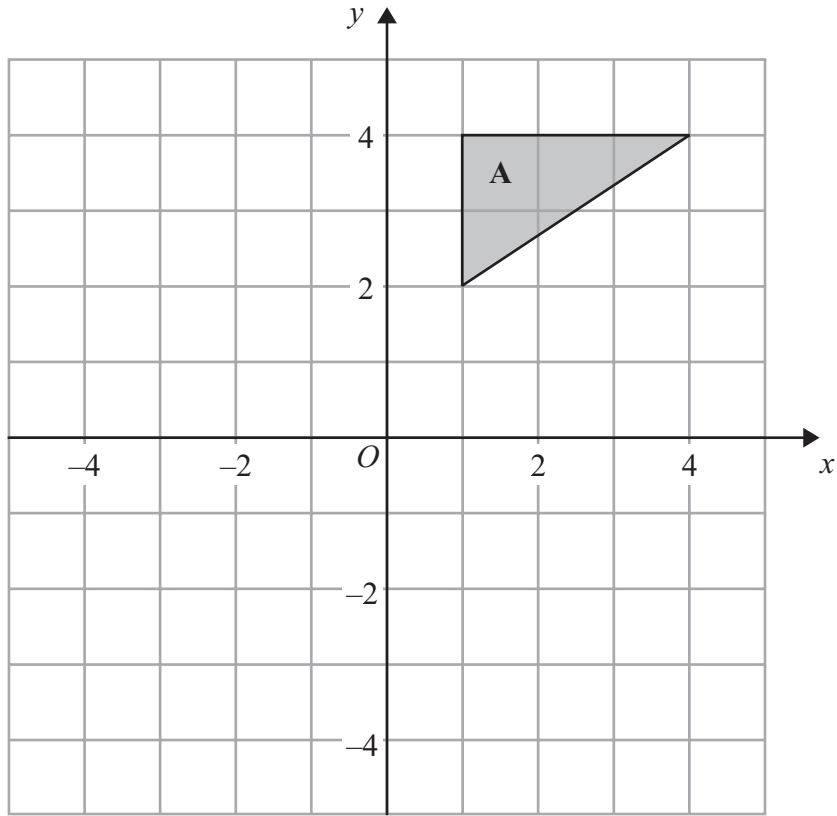

(a) Rotate triangle **A** 90° clockwise, centre O .

(2)

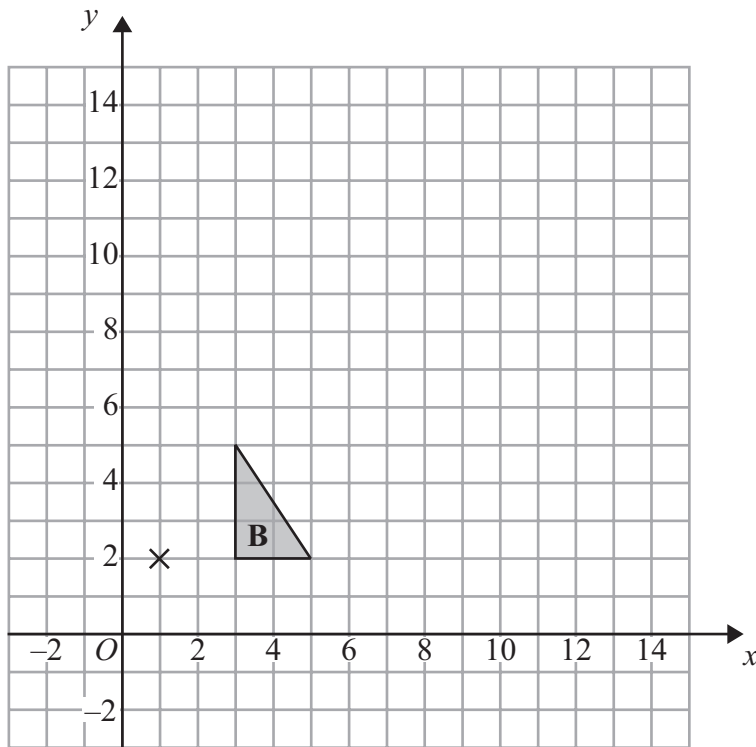

(b) Enlarge triangle **B** by scale factor 3, centre $(1, 2)$.

(3)

(Total for Question 8 is 5 marks)



- 9 Linda is going on holiday to the Czech Republic.
She needs to change some money into koruna.

She can only change her money into 100 koruna notes.

Linda only wants to change up to £200 into koruna.
She wants as many 100 koruna notes as possible.

The exchange rate is £1 = 25.82 koruna.

How many 100 koruna notes should she get?

.....
(Total for Question 9 is 3 marks)

- 10 m is an integer such that $-2 < m \leq 3$

(a) Write down all the possible values of m .

.....
(2)

(b) Solve $7x - 9 < 3x + 4$

.....
(2)

(Total for Question 10 is 4 marks)



11 The equation

$$x^3 - 6x = 72$$

has a solution between 4 and 5

Use a trial and improvement method to find this solution.

Give your answer correct to one decimal place.

You must show **all** your working.

$x = \dots\dots\dots$

(Total for Question 11 is 4 marks)



12 The probability that a biased dice will land on a five is 0.3

Megan is going to roll the dice 400 times.

Work out an estimate for the number of times the dice will land on a five.

.....
(Total for Question 12 is 2 marks)

13 Bob asked each of 40 friends how many minutes they took to get to work.

The table shows some information about his results.

Time taken (m minutes)	Frequency
$0 < m \leq 10$	3
$10 < m \leq 20$	8
$20 < m \leq 30$	11
$30 < m \leq 40$	9
$40 < m \leq 50$	9

Work out an estimate for the mean time taken.

..... minutes

(Total for Question 13 is 4 marks)



14 (a) Expand and simplify $(p + 9)(p - 4)$

.....
(2)

(b) Solve $\frac{5w - 8}{3} = 4w + 2$

$w =$
(3)

(c) Factorise $x^2 - 49$

.....
(1)

(d) Simplify $(9x^8y^3)^{\frac{1}{2}}$

.....
(2)

(Total for Question 14 is 8 marks)



*15 Henry is thinking about having a water meter.

These are the two ways he can pay for the water he uses.

Water Meter

A charge of £28.20 per year

plus

91.22p for every cubic metre of water used

1 cubic metre = 1000 litres

No Water Meter

A charge of £107 per year

Henry uses an average of 180 litres of water each day.

Henry wants to pay as little as possible for the water he uses.

Should Henry have a water meter?

(Total for Question 15 is 5 marks)



16

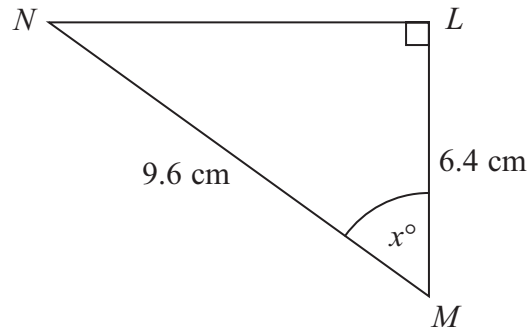

Diagram **NOT** accurately drawn

LMN is a right-angled triangle.

$MN = 9.6$ cm.

$LM = 6.4$ cm.

Calculate the size of the angle marked x° .

Give your answer correct to 1 decimal place.

.....^o

(Total for Question 16 is 3 marks)

17 Liam invests £6200 for 3 years in a savings account.

He gets 2.5% per annum compound interest.

How much money will Liam have in his savings account at the end of 3 years?

£.....

(Total for Question 17 is 3 marks)



18 The diagram shows a quadrilateral $ABCD$.

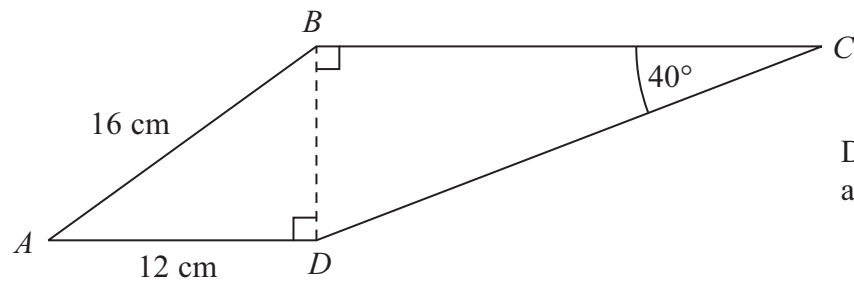

Diagram NOT accurately drawn

$AB = 16$ cm.

$AD = 12$ cm.

Angle $BCD = 40^\circ$.

Angle $ADB = \text{angle } CBD = 90^\circ$.

Calculate the length of CD .

Give your answer correct to 3 significant figures.

..... cm

(Total for Question 18 is 5 marks)



19

$$p^2 = \frac{x - y}{xy}$$

$$x = 8.5 \times 10^9$$

$$y = 4 \times 10^8$$

Find the value of p .

Give your answer in standard form correct to 2 significant figures.

.....
(Total for Question 19 is 3 marks)

20 Make t the subject of the formula $2(d - t) = 4t + 7$

$t =$

(Total for Question 20 is 3 marks)



21 Prove that

$$(2n + 3)^2 - (2n - 3)^2 \text{ is a multiple of } 8$$

for all positive integer values of n .

(Total for Question 21 is 3 marks)

22 Solve $3x^2 - 4x - 2 = 0$

Give your solutions correct to 3 significant figures.

(Total for Question 22 is 3 marks)



23 (a) Max wants to take a random sample of students from his year group.

(i) Explain what is meant by a random sample.

.....

.....

.....

(ii) Describe a method Max could use to take his random sample.

.....

.....

.....

(2)

(b) The table below shows the numbers of students in 5 year groups at a school.

Year	Number of students
9	239
10	257
11	248
12	190
13	206

Lisa takes a stratified sample of 100 students by year group.

Work out the number of students from Year 9 she has in her sample.

.....

(2)

(Total for Question 23 is 4 marks)



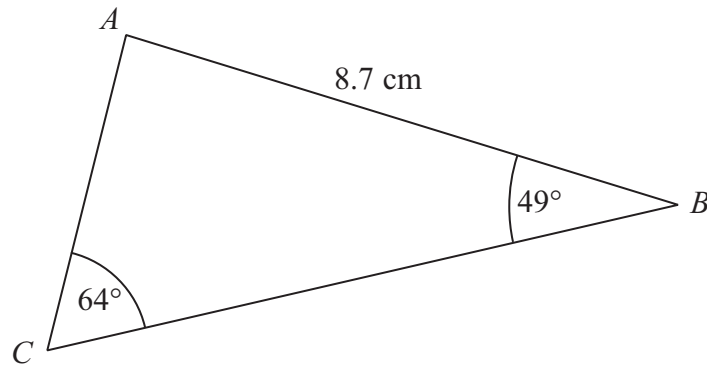

Diagram **NOT**
accurately drawn

ABC is a triangle.

$AB = 8.7$ cm.

Angle $ABC = 49^\circ$.

Angle $ACB = 64^\circ$.

Calculate the area of triangle ABC .

Give your answer correct to 3 significant figures.

.....cm²

(Total for Question 24 is 5 marks)



25 Carolyn has 20 biscuits in a tin.

She has

- 12 plain biscuits
- 5 chocolate biscuits
- 3 ginger biscuits

Carolyn takes at random two biscuits from the tin.

Work out the probability that the two biscuits were **not** the same type.

.....
(Total for Question 25 is 4 marks)



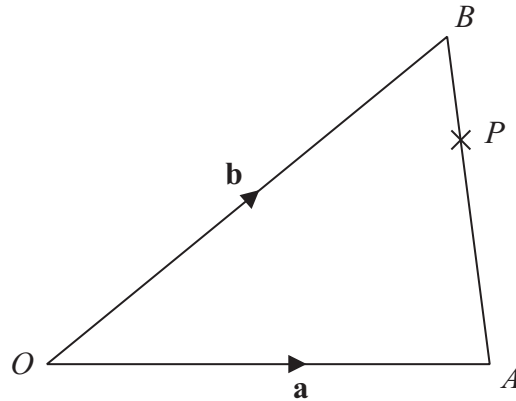

Diagram **NOT**
accurately drawn

OAB is a triangle.

$$\vec{OA} = \mathbf{a}$$

$$\vec{OB} = \mathbf{b}$$

(a) Find \vec{AB} in terms of \mathbf{a} and \mathbf{b} .

.....
(1)

P is the point on AB such that $AP : PB = 3 : 1$

(b) Find \vec{OP} in terms of \mathbf{a} and \mathbf{b} .

Give your answer in its simplest form.

.....
(3)

(Total for Question 26 is 4 marks)

TOTAL FOR PAPER IS 100 MARKS



BLANK PAGE

